



Dust extracting bench with double dry filtering system



suction bench

CERTIFIED

XAERO
Sound pressure: 77 db(A)

XAGUA
Sound pressure: 73,5 db(A)



Section of Xagua bench



suction bench

- **Strong suction power**
- **Minimal foot print**
- **Compact design**, without chimneys, hoods or cumbersome structures, allowing to work even largest stone slabs.

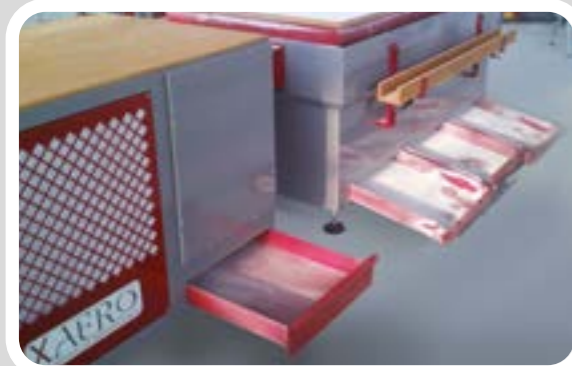

Maintenance

The double dry filtering system of XAERO extremely eases the maintenance: you just have to take out the dust drawers

The physical principle: the CYCLONS extract over 70% of the captured dust without need of any maintenance

The mechanical principle: the FILTER CARTRIDGE retains the remaining dust, thus guaranteeing total filtering



Dust extracting bench with water depuration

TECHNICAL FEATURES

Dimensions and weight

- Extracting unit: 2230 x 940 x 1140 mm, weight 370 kg
- Suction unit: 1400 x 940 x 940 mm, weight 300 kg
- Dimensions of the two unites directly assembled: 3630 x 940 x 1140 mm, weight 700 kg

Electrical system

- Power supply: 400 V - 50 Hz three-phase (other voltages on request)
- Electrical absorption 5,5 kW

Pneumatic system

- driven by an electronic master unit, activating the filter cartridge cleaning cycles
- Minimum required air pressure: 8 bar
- Optional 1 flexible suction arm

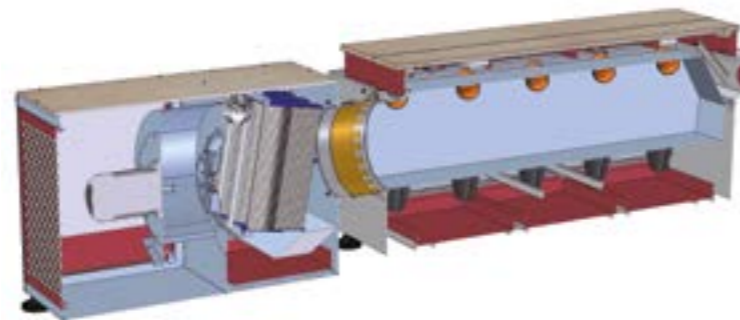

Section of Xaero bench

TECHNICAL FEATURES

Power supply

400 V - 50 Hz three-phase, electrical absorption 4 kW
230 V - 60 Hz three-phase, electrical absorption 4 kW (other voltages on request).

Dimensions: 2990 x 1110 x 920 mm

Weight: 650 kg (approx.)

Standard equipment

- 1 slab holder adjustable in height and distance from the bench, it can be fitted on both sides of the workbench.
- 1 interlocked single-phase socket for electric tools.

- Optional 1 flexible suction arm

Simple maintenance

Thanks to innovative technologies, GHINES products do not have pumps, filters or mechanical moving parts, thus reducing maintenance to minimum